

# HIGUMA®

	ONE AUGER					TWO AUGERS					
	HIGUMA 5/1-A	HIGUMA 8/1-A	HIGUMA 10/1-A	HIGUMA 12/1-A	HIGUMA 14/1-A	HIGUMA 12/2-A	HIGUMA 14/2-A	HIGUMA 16/2-A	HIGUMA 18/2-A	HIGUMA 20/2-A	
Capacity	m³	5	8	10	12	14	12	14	16	18	20
Quantity of augers		1	1	1	1	1	2	2	2	2	2
Length	mm	3800	4300	4500	4700	4800	7000	7100	7200	7300	7600
Width tank	mm	1700	2100	2200	2350	2350	2100	2100	2100	2100	2200
Height	mm	2500	2650	2750	2850	3100	2250	2450	2650	2850	2800
Wheels size		30.11-14.5	245/70-17.5	245/70-17.5	245/70-17.5	245/70-17.5	245/70-17.5	245/70-17.5	215/75-17.5	215/75-17.5	215/75-17.5
Quantity of axles		1	1	1	1	1	1	1	1	1	1
Quantity of wheels		2	2	2	2	2	2	2	4	4	4
Required power	HP	45	60	70	80	100	70	80	90	100	120
PTO revs	rpm	540	540	540	540	540	540	540	540	540	540
Weight	Kg	2200	3000	3100	3500	3600	5000	5500	6000	6400	7000

# KODIAK®

	ONE AUGER								
	KODIAK z10/1	KODIAK 12/1	KODIAK 14/1	KODIAK 16/1	KODIAK 18/1	KODIAK 20/1	KODIAK 22/1		
Capacity	m³	10	12	14	16	18	20	22	
Quantity of augers		1	1	1	1	1	1	1	
Length	mm	5500	5650	5650	5650	6150	6150	6150	
Width max.	mm	2350	2500	2500	2500	2800	2800	2800	
Height	mm	2700	2850	3050	3200	3000	3200	3400	
Wheel track	mm	1550	1700	1700	1700	2000	2000	2000	
Quantity of axles		1	1	1	1	1	1	1	
Quantity of wheels		2	2	2	4	4	4	4	
Wheels size		245/70-17.5	245/70-17.5	245/70-17.5	215/75-17.5	215/75-17.5	215/75-17.5	215/75-17.5	
Required power	HP	60	70	80	90	100	110	120	
PTO revs	rpm	540	540	540	540	540	540	540	
Weight	kg	4000	4700	5400	5700	6200	6400	6700	

	TWO AUGERS						
	KODIAK 16/2	KODIAK 20/2	KODIAK 25/2	KODIAK 30/2	KODIAK 30/2	KODIAK 40/2	
Capacity	m³	16	20	25	30	35	40
Quantity of augers		2	2	2	2	2	2
Length	mm	7300	7600	8000	8100	8200	8800
Width max.	mm	2100	2350	2500	2500	2500	2800
Height	mm	2650	2650	2850	3100	3400	3450
Wheel track	mm	1550	1600	1700	1700	1700	2000
Quantity of axles		1	1	2	2	2	2
Quantity of wheels		4	4	8	8	8	8
Wheels size		215/75-17.5	215/75-17.5	215/75-17.5	215/75-17.5	215/75-17.5	215/75-17.5
Required power	HP	80	110	130	150	150	180
PTO revs	rpm	540	540	540	540	540	540
Weight	kg	6600	7000	9500	10000	10500	12000

	THREE AUGERS			
	KODIAK 40/3	KODIAK 45/3	KODIAK 48/3	
Capacity	m³	40	45	48
Number of augers		3	3	3
Length	mm	11200	11500	12000
Width	mm	2500	2500	2500
Height	mm	3000	3400	3600
Wheel track	mm	2450	2450	2450
Number of axles		2	TRIDEM	TRIDEM
Number of fixed axles		1	1	1
Number of steering axles		1	2	2
Pneumatic brakes and springs		Optional - O09	Standard	Standard
Wheels size		215/75-17.5	385/55-19.5	385/55-19.5
Number of wheels		8 twins	6 single wheels	6 single wheels
Number of load cells		6	6	6
Required power	HP	180	200	220
PTO revs	rpm	540	540	540
Weight	Kg	13500	15000	16000



# KODIAK-HIGUMA

Vertical trailed mixer feeders



+39 0377 430 405

sgariboldi.it

info@sgariboldi.it

Sgariboldi

SgariboldiOfficial

+39 0377 430 415

marketing@sgariboldi.it

sgariboldi.official

SGARIBOLDI Srl



Download on the App Store | Get it on Google Play

www.sgariboldi.it

SGARIBOLDI S.r.l. Via Pietro Nenni 15 | 26845 Codogno - Lodi (Italy)





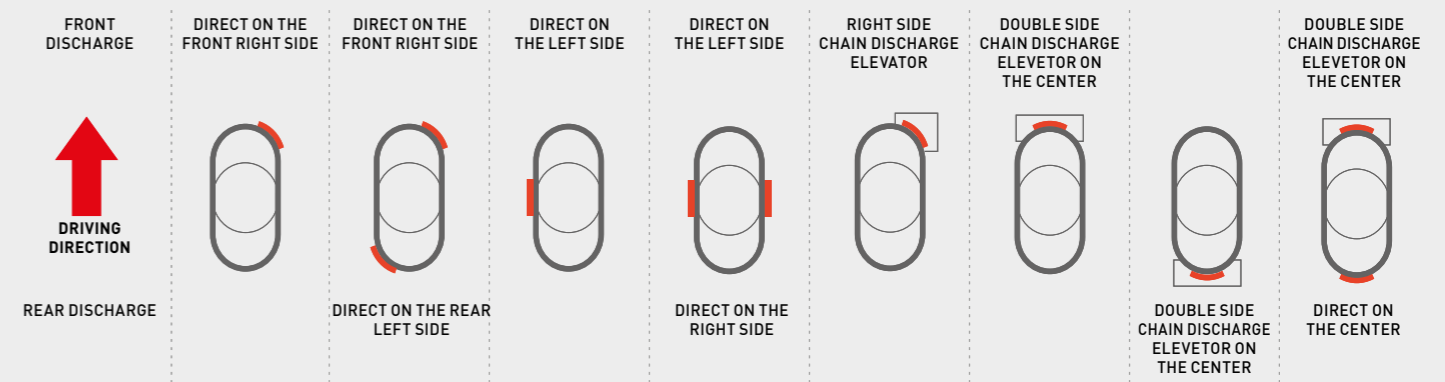

# VS2 VERTICAL TECHNOLOGY

Sgariboldi develops vertical diet feeders with exceptional mixing performance and maintenance features, ideal for cut hay or straw bales of any size, shape, and weight, and are suitable for any work requirements.

The **mixing tank** shape handles the ingredients flows to get quickly the best mixture, preserving the structure of any commodity.

Counter-knives in the mixing tank: they ensure clean cut of fibrous products

Uniform and precise ration discharge

The conic auger along with special knives, allows:

- The cut of long fibre products
- The swift flaking off of any bales
- Reduced working times by avoiding overheating in the mix
- The retention of an excellent fodder value and excellent ration softness

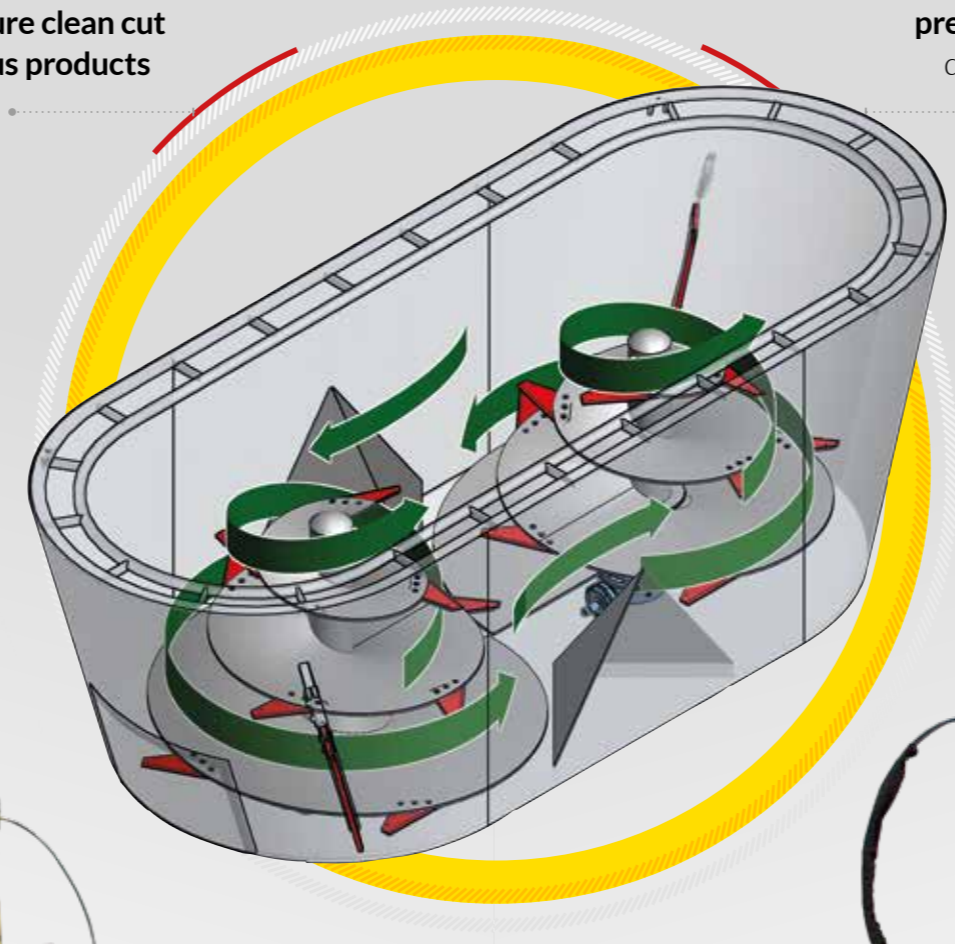

01 Available with an electric or diesel engine and in a stationary version\*

02 Rotating magnet on the discharge elevator

03 Programmable weight indicator\*

04 Electric distributors\*

05 Pneumatic brakes\*

06 Hopper for concentrates

